

### INSTALLATION INSTRUCTIONS CONDUCTIVE COMPRESSION X THREADED ADAPTER COUPLINGS

#### IMPORTANT

Pressure Rating: 300 psig MAOP

Operating Temperature: -20 to 140° F

Material: Carbon Steel

#### THREADED END

1. APPLY A GOOD GRADE OF THREAD SEALANT OR LUBRICANT TO THREADS.
2. TIGHTEN JOINT LEAK TIGHT.

#### CONDUCTIVE COMPRESSION END (3/4" IPS & LARGER)

3. CLEAN METALLIC PIPE ENDS THOROUGHLY. REMOVE ANY COATINGS, DIRT, ETC.
4. LOOSEN COMPRESSION NUT AND INSERT PIPE UNTIL IT BOTTOMS IN COUPLING. PIPE MISALIGNMENT SHALL BE NO MORE THAN 3 1/2°.
5. TIGHTEN COMPRESSION NUT TO THE TORQUE VALUES LISTED.

Size	Torque Ftlbs	Metallic Pipe Pullout Resistance
3/4" IPS	120-140	575 lbs
1" IPS	120-140	900 lbs
1 1/4" IPS	280-300	1,000 lbs

**NOTE:** THE CONDUCTIVE COMPRESSION END IS NOT A FULL RESTRAINT JOINT. WHERE PIPE PULLOUT COULD OCCUR, THE PIPE JOINT MUST BE ANCHORED.

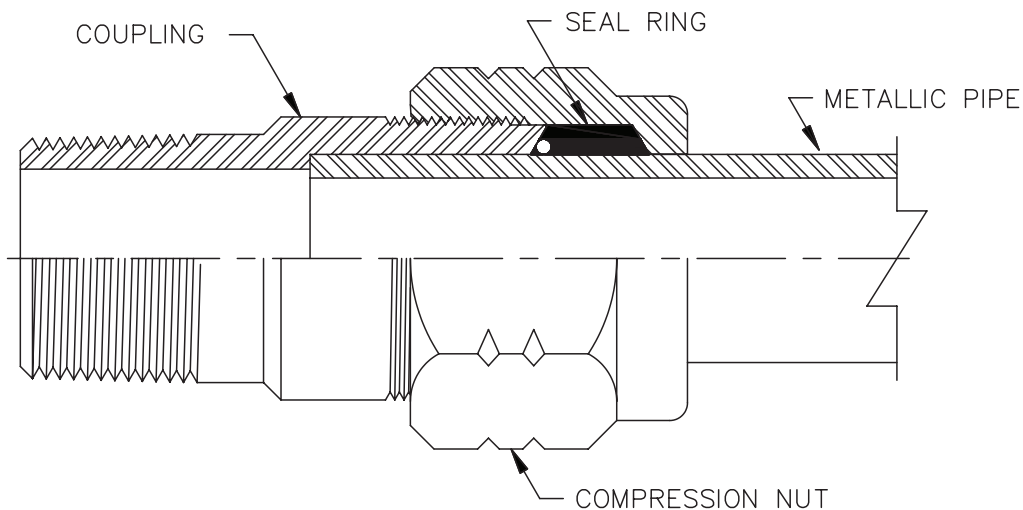

ECN 2620 REV "D" 07/23/14